

UW-1412-WO Series Straddle Urinal Washout Type

| ✓ | MODEL NUMBER | FLUSH TYPE | INLET LOCATION |
|---|---------------|------------|----------------|
| | UW-1412-WO-BS | WASHOUT | BACK |
| | UW-1412-WO-TS | WASHOUT | TOP |

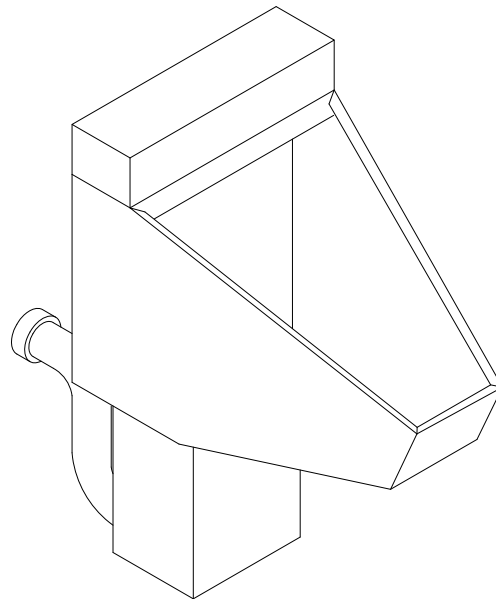

Recommended Specifications

Wall hung straddle urinal shall be Willoughby Model No. **UW-1412-WO-__** (select from table above).

Fixture shall be fabricated from 14 gauge, type 304 stainless steel. The construction shall be all-welded, with exposed stainless surfaces polished to a #4 satin finish.

Standard equipment shall include: full perimeter 360 de-

gree flushing rim, beehive strainer and integral stainless steel p-trap. Urinal shall be washout type which requires 25 psi minimum flushing pressure. Trap shall be fully enclosed, maintain a 3" seal and pass a 1.9" ball.

Anchoring shall be by standard 4-point system: threaded rods, nuts and washers furnished for walls up to 8" thick. Unit requires chase area for installation and maintenance.

Visit our website at <http://www.willoughby-ind.com>

2210 West Morris Street • P.O. Box 21217 • Indianapolis, IN 46221
(317) 638-2381 • Fax: (317) 638-6110 • (800) 428-4065

MODEL NUMBER AND OPTIONS:

1.) Urinal Waste Location:

- UW Wall Outlet

2.) Base Model Number:

- 1412 Straddle Urinal

3.) Flush Type:

- WO Wash-out

4.) Inlet Location:

- BS Back Spud
 TS Top Spud

5.) Options:

- MT Metal Template
 WS Wall Sleeve
 FV Flush Valve
 FVC Flush Valve Cover (Top Spud)
 FVT Flush Valve Thru-Wall Connection (Requires Back Spud Option)
 AP Flush Valve Access Panel
 Other: _____
 Other: _____

Drawing Approved For Manufacturing By: _____ Date: _____ Company: _____
 Wall Thickness: _____ Wall Type: _____

VERIFY ALL DIMENSIONS PRIOR TO ROUGH-IN

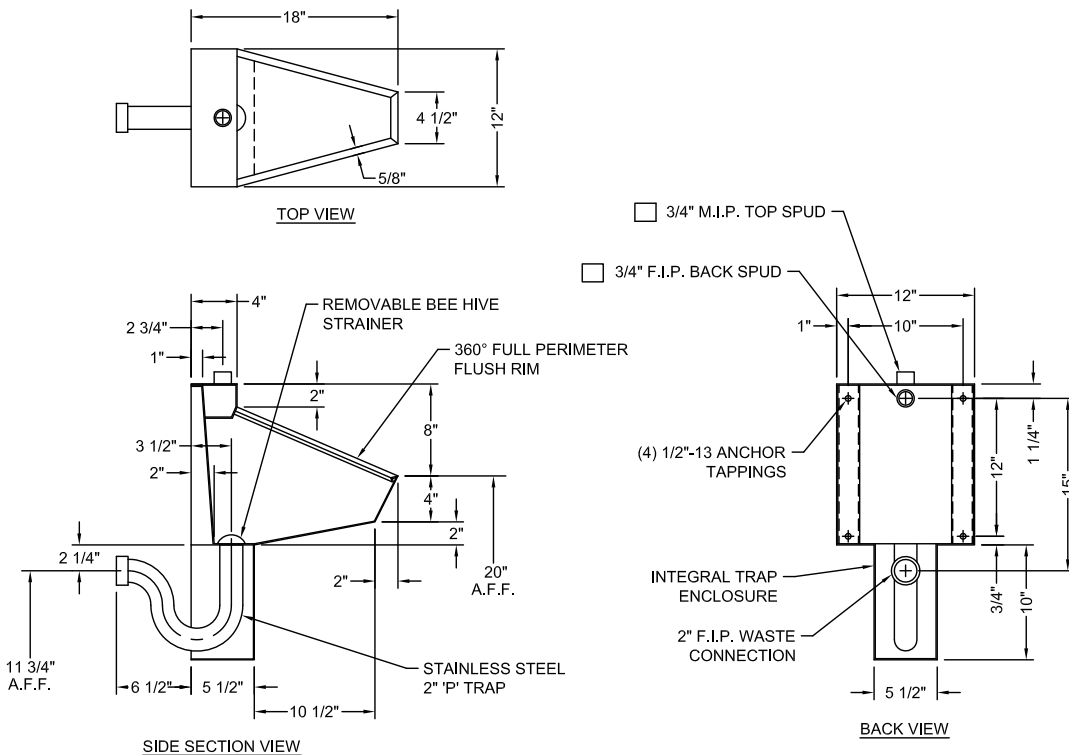

To specify fixture and accessories, use the Model Number and Options Guide.
 Example: To specify a UW-1412-WO straddle urinal with back spud.
 Use the following Willoughby Model Number:
 Willoughby Model Number: UW-1412-WO-BS

Willoughby Industries, Inc.