

LFCETW-1490-OF-BS TOILET

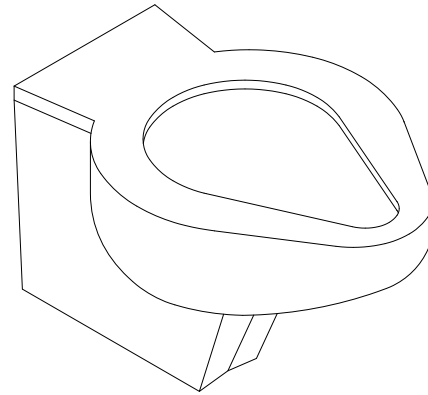

Recommended Specifications

Toilet shall be Willoughby Model No. **LFCETW-1490-OF-BS**

Fixture shall be fabricated from 14 gauge, type 304 stainless steel. The construction shall be all-welded, with exposed stainless surfaces having a bead blast finish. Toilet seat shall be integral and shall be polished to a #4 satin finish. Weld seams shall be smooth as-welded.

Standard low flow (1.6 gpf) toilet shall include: elongated toilet bowl with integral contoured seat, integral crevice-free self-draining flushing rim with positive afterfill and fully enclosed 2 1/2 (64mm) O.D. trap which shall maintain a minimum 3 1/2" (89mm) seal and pass a 2 1/8" (54mm) ball. Toilet shall have integral flush inlet and waste outlet extensions. Toilet shall be blowout type which requires 25 psi minimum flushing pressure.

Fixture shall withstand loadings up to 2,000 lbs. with no measurable deflection and loadings up to 5,000 lbs. with no permanent damage.

Anchoring shall be by standard 4-point system: threaded rods, nuts and washers shall be furnished. Unit is wall hung and shall require chase area for installation and maintenance. Flush valve pushbutton assembly shall be mounted to side of fixture cabinet with security screws.

Visit our website at <http://www.willoughby-ind.com>

2210 West Morris Street • P.O. Box 21217 • Indianapolis, IN 46221
(317) 638-2381 • Fax: (317) 638-6110 • (800) 428-4065

MODEL NUMBER AND OPTIONS:

1.) Toilet Waste Location:

LFCETW Wall, Blowout, 1.6 GPF

2.) Base Model Number:

1490

3.) Fixture Mounting:

OF Off Floor Mounted

4.) Inlet Location:

BS Back Spud

5.) Options:

FV Flush Valve

AP Flush Valve Access Panel

HPS High Polish Seat

MT Metal Template

RTH1 Wall Mounted Recessed Tissue Holder

RTH2 Wall Mounted Recessed Tissue Holder (Front Access)

T4 Top-Four Overflow Preventer
(Requires Hydraulic Flush Valve)

WS Wall Sleeve

Other: _____

Other: _____

Drawing Approved For Manufacturing By: _____ Date: _____ Company: _____
Wall Thickness _____ Wall Type _____

VERIFY ALL DIMENSIONS PRIOR TO ROUGH-IN

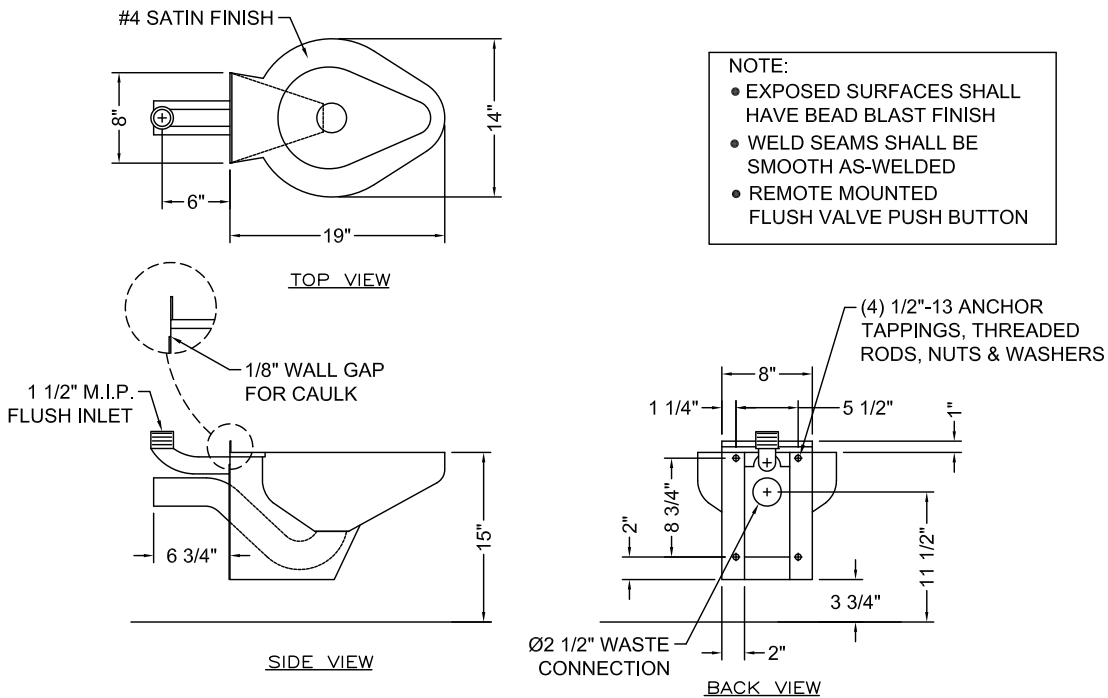

Willoughby Industries, Inc.