

## EWSSS-Series Surgical Scrub Sink

✓	MODEL	LENGTH	WIDTH	NUMBER OF STATIONS
	EWSSS-1	30"	23"	1
	EWSSS-2	60"	23"	2
	EWSSS-3	90"	23"	3

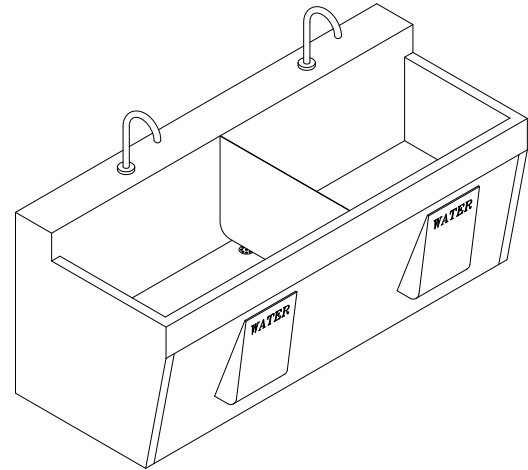

(Some options may be shown)

### Recommended Specifications

Economy - Knee Activated Surgical Scrub Sink shall be Willoughby model no. **EWSSS-**\_ (select from table above).

Fixture shall be fabricated from 16 gauge type 304 stainless steel. The construction shall be all-welded with exposed exterior stainless steel surfaces polished to a #4 satin finish. Bowl(s) shall have bead-blast finish.

Standard equipment shall include: knee-activated mechanical pilot type water valve(s) activated by one push of a knee operated front panel and turned off by a second push, swivel aerator spray head, (inline) integral checkstop, #480 Thermo-Mix valve, 1 1/2" strainer drain with tailpiece, 1 1/2" F.I.P. slip joint, cast brass union p-trap.

Anchoring shall be from the front, with rear mounted "z"-clips and anchoring hardware by others. Unit requires no chase area for installation and maintenance. Two and three station shall include divider panels.

#### Optional Features

- Liquid Soap System - Knee Activated
- Mounting Carrier
- Mounting Base
- Laminar Flow Nozzle

#### Mechanical Requirements

- 1/2" MIP hot and cold supplies
- 1 1/2" FIP drain connection

Visit our website at <http://www.willoughby-ind.com>

2210 West Morris Street • P.O. Box 21217 • Indianapolis, IN 46221

(317) 638-2381 • Fax: (317) 638-6110 • (800) 428-4065

# MODEL NUMBER AND OPTIONS:

## 1.) Series:

EWSSS Surgical Scrub Sink

## 2.) Stations:

- 1 One Station  
 2 Two Station (with 1 divider panel)  
 3 Three Station (with 2 divider panels)

## 3.) Actuation:

- KA Knee Actuated  
 IR Sensor Actuated  
 (includes plug-in transformer)  
 BBO Body Bar Actuated

## 4.) Mounting:

- MC Mounting Carrier (off-floor installation)  
 MB Mounting Base (on-floor installation)

## 4.) Options

- LSD Liquid Soap Dispenser(s), Knee activated  
 PB Pressure Balancing Valve(s) (Above Deck)  
 AD-TSV Thermostatic Mixing Valve(s) (Above Deck)  
 LFN Laminar Flow Nozzle  
 Other: \_\_\_\_\_  
 Other: \_\_\_\_\_

Drawing Approved For Manufacturing By: \_\_\_\_\_ Date: \_\_\_\_\_ Company: \_\_\_\_\_

Wall Thickness: \_\_\_\_\_ Wall Type: \_\_\_\_\_

**VERIFY ALL DIMENSIONS PRIOR TO ROUGH-IN**

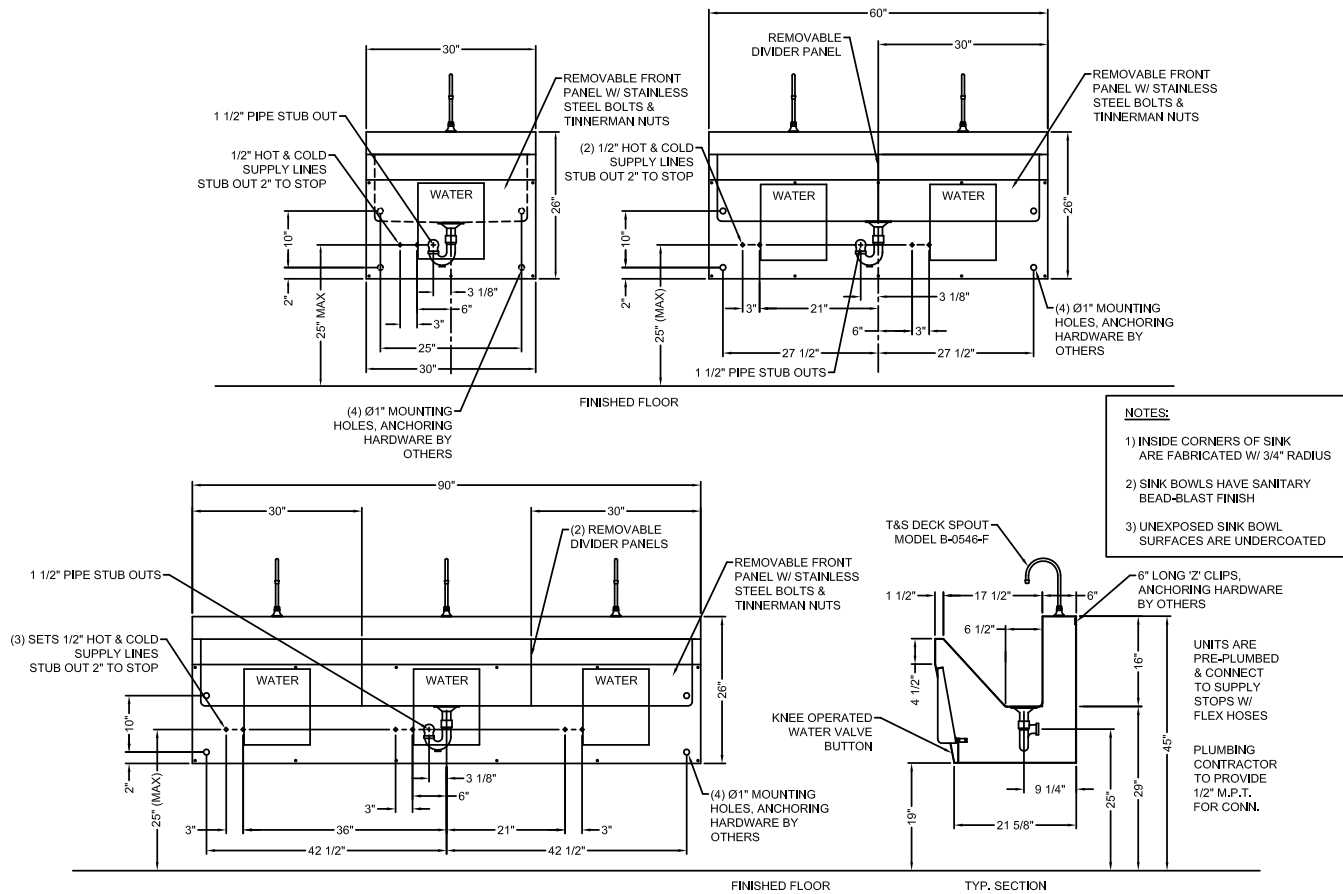

# Willoughby Industries, Inc.