

DF3-1850-96-HC-FA 3 Station Front Access Drinking Fountain

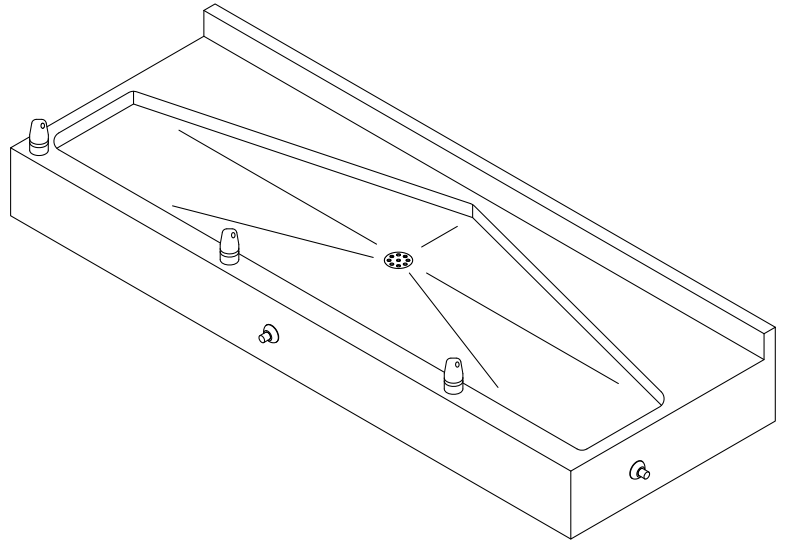

Recommended Specifications

Drinking Fountain shall be Willoughby Model No. DF3-1850-96-HC-FA.

Fixture shall be fabricated of 14 gauge, type 304 stainless steel, seamlessly welded and polished to a #4 satin finish. Fixture is designed for installation and service from front of finished wall. Unit meets all ADA, UFAS, and ANSI standards for accessibility.

Unit shall have three bubblers with mouth-guard, each controlled by one Willoughby PS-1 (which requires less than 5 psi push to activate), manifolded to allow for one single water inlet. 50" x 18-1/4", unit shall have elbow and 1-1/4" tubular waste. Fountain shall allow for installation and maintenance through removable bottom panel. Mounting brackets are supplied, mounting anchors are by others.

Vandal Resistance:

All pushbuttons and escutcheons are secured to the unit from within the fixture. Valves, water supplies, and waste connections are concealed within. The bottom panel is removable and secured with vandal resistant security torx screws.

ADA, UFAS and ANSI Compliant:

When the drinking fountain is mounted at standard 36" bubbler height, it is designed to comply with applicable ADA, UFAS and ANSI Z124.3 and Z124.6 accessibility guidelines.

Optional Features:

Willoughby drinking fountains can also be supplied for use by juveniles.

Visit our website at <http://www.willoughby-ind.com>

2210 West Morris Street • P.O. Box 21217 • Indianapolis, IN 46221

(317) 638-2381 • Fax: (317) 638-6110 • (800) 428-4065

MODEL NUMBER AND OPTIONS:

1.) Drinking Fountain Type:

DF3

2.) Base Model Number:

1850 50" Drinking Fountain

3.) Front Access:

FA Front Access

4.) Bubbler or Spout Selection:

DB Drinking Fountain Bubbler

5.) Valve Selection:

PS1 Single Temp. Pneu.
Self-Closing

6.) Other Options:

- MT Metal Template
- PPB Palm Pushbutton
- WPB Stainless Steel Wall Backpanel
- Other: _____
- Other: _____

Drawing Approved For Manufacturing By: _____ Date: _____ Company: _____
 Wall Thickness: _____ Wall Type: _____

VERIFY ALL DIMENSIONS PRIOR TO ROUGH-IN

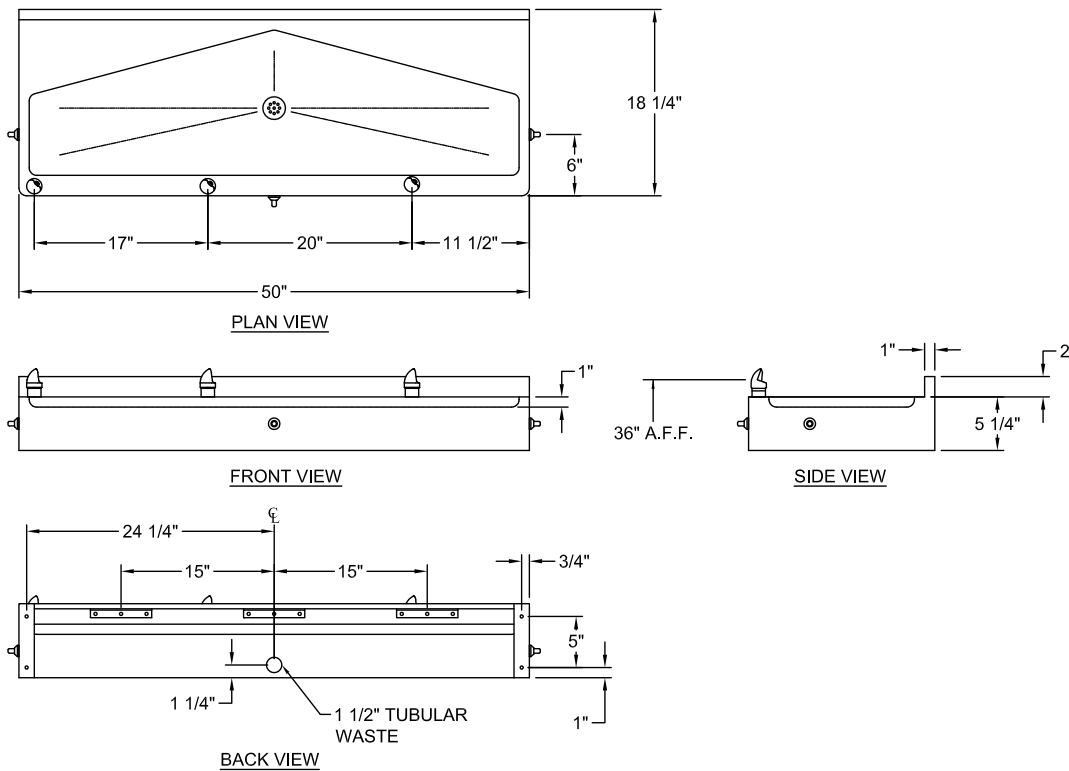

To specify fixture and accessories, use the Model Number and Options Guide.
 Example: To specify an DF3-1850-96-HC-FA drinking fountain with drinking fountain bubbler, single temp. pneumatic self-closing valve, and wall sleeve. Use the following Willoughby Model Number:
 Willoughby Model Number: DF3-1850-96-HC-FA-DB-PS1-WS

Willoughby Industries, Inc.