

Aquasurf® Solid Surface Shower Receptors

Square, Rectangular

✓	MODEL NUMBER	SIZE
	AS-S3636	36" x 36" SQUARE
	AS-S3648	36" x 48" RECTANGULAR
	AS-S3660	36" x 60" RECTANGULAR

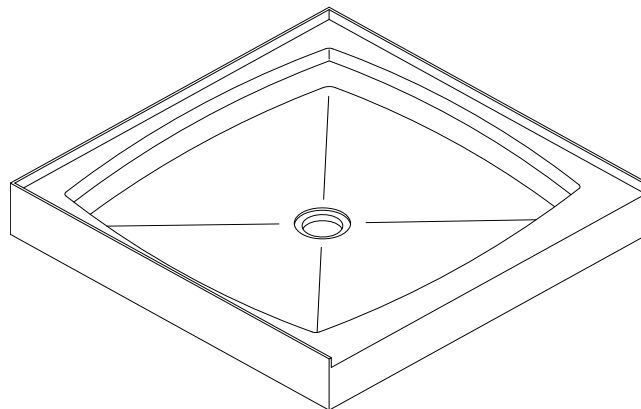

36x36 Square Shown

Recommended Specifications _____

Solid Surface Shower Receptor shall be Aquasurf® Solid Surface Products monolithic cast model #AS-S_____(select from table).

Aquasurf® Solid Surface Products Shower Receptors are designed for single and multiple applications. The Shower Receptor shall be a monolithic cast component of Aquasurf® Solid Surface Products polymer materials, composed of fully densified aluminum trihydrate mineral fillers, homogeneously blended in a engineered, UV stabilized, acrylic modified polyester resin.

Shower Receptor shall have integrally molded support bracing on bottom, positive sloped non-slip textured interior floor, and integral perimeter flange. Aquasurf® Solid Surface Products Shower Receptors shall incorporate, integral threshold, and curb, and 3 1/2" standard drain opening, (for 2" No-Hub connection).

Shower Receptor shall be available in Solid Color or Granite Pattern (indicate color selection). Solid Surface Shower Receptor shall comply with ANSI Z124.2.

Vandal Resistance:

Aquasurf® Solid Surface Products Shower Receptors offer high impact, chip, scratch, and burn resistance. Topical surface damages can easily be repaired with minor abrasive applications (3M #7448 Scotch-Brite®). The viral, bacteriological, chemical, mildew, and mold resistance provides a sanitary, easily cleaned, durable, low maintenance component.

Optional Features:

Aquasurf® Solid Surface Products wall panel kits with overlay battens, coved corners; soap/shampoo assemblies provide all components required to complete shower area enclosure (refer to selection sheet for unit designation).

Visit our website at <http://www.willoughby-ind.com>

2210 West Morris Street • P.O. Box 21217 • Indianapolis, IN 46221

(317) 638-2381 • Fax: (317) 638-6110 • (800) 428-4065

MODEL NUMBER AND OPTIONS:

1.) Receptacle Type:

- AS-S3636 36x36 Square Pan
- AS-S4836 48x36 Rectangular Pan
- AS-S6036 60x36 Rectangular Pan

2.) Wall Kits (3/8" Panels):

- ASK-S363672 (3)-36x72 Panels
- ASK-S483672 (2)-36x72 Panels
(1)-48x72 Panel
- ASK-S603672 (2)-36x72 Panels
(2)-29x72 Panels
(1)-AS-B0272 Batten Trim

3.) Commercial Wall Kits (1/4" Panels):

- ASK-S363684 (3)-36x84 Panels
- ASK-S483684 (2)-36x84 Panels
(2)-24x84 Panel
(1)-AS-B0296 Batten Trim
- ASK-S603684 (2)-36x84 Panels
(2)-29x84 Panels
(1)-AS-B0296 Batten Trim

4.) Accessories:

- AS-ISCR Inside Corner Overlay Trim
- AS-IS-CV8 Inside Corner Cove Overlay
- ASK-UP84 Upgrade Kit to 84"
- AS-SSH Soap/Shampoo Holder

Drawing Approved For Manufacturing By: _____ Date: _____ Company: _____
 Wall Thickness: _____ Wall Type: _____

VERIFY ALL DIMENSIONS PRIOR TO ROUGH-IN

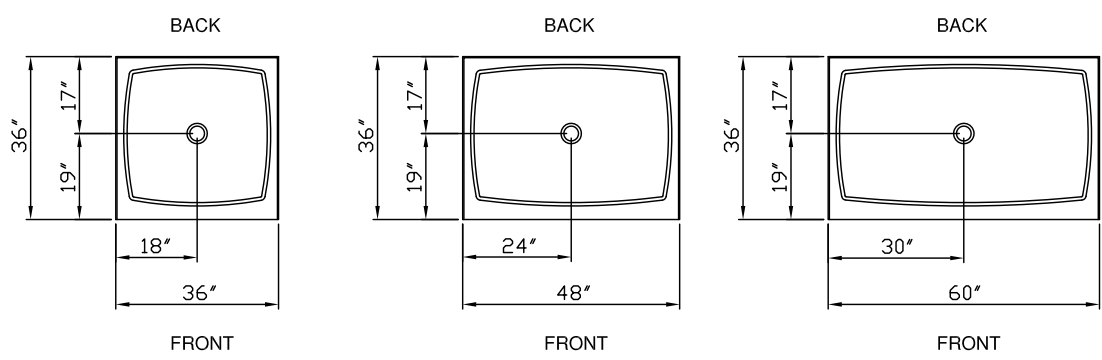
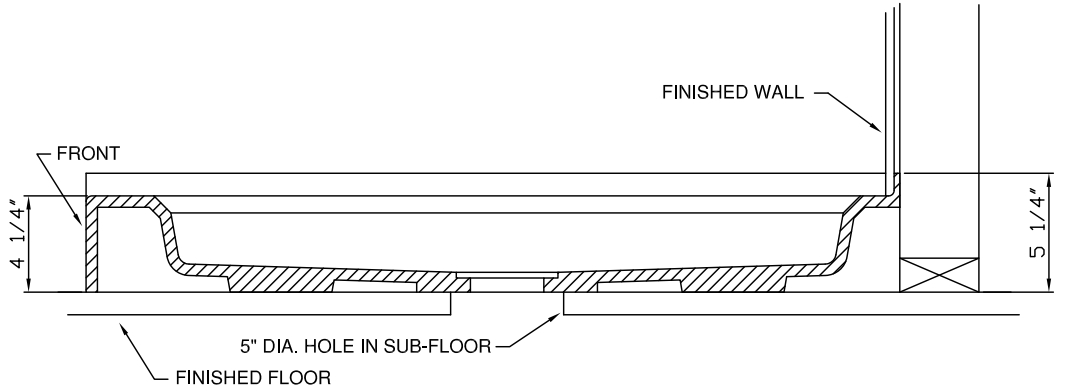

Willoughby Industries, Inc.